

TECHNICAL INFO



Magnetic Float Level Transmitter
Techfloat - LTF

INTRODUCTION

PRINCIPLE

The "Magnet Float Level Transmitter" is composed of the float and sensing rod (shown as below). As the float raised or lowered by liquid level, the sensing rod will have a resistance output, which is directly proportional to the liquid level. Also, the float level indicator can be equipped with the TAB-2100 (please see page 3) to produce a 0/4~20mA signal. In addition, we can use with PB series bargraphic display scaling panel meter for level control and display. Anyway, "Magnet Float Level Indicator" is a great benefit to all kinds of industries with its easy working principle and reliability.

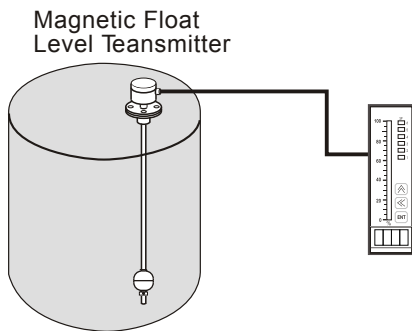

FEATURES

- Every sensing element is protected by a plastic package, safety in use and transport. (as fig. 1)
- High performance and reliability of electric circuit modular designed (as fig.2).
- Lower installation costs, less maintenance, reduced personnel training, and decreased plant shock down time.
- Explosion Proof
- Marine Proof, ABS, DNV, BV, LR, GL

APPLICATIONS

Applied for waste water treatment turn-key facility, electric power plant, shipping vessel, hydraulic facility, chemical industrial equipment, petrochemical industry and hot coal boiler. e.g. diesel engine generator, motor oil meter, oil material storage tank.

SCHEMATIC DIAGRAM OF THE PRINCIPLES

1. Sensing Rod
2. Float
3. Transmitter
4. Display Unit

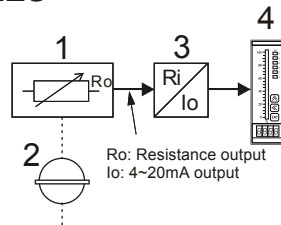

CONSTRUCTION

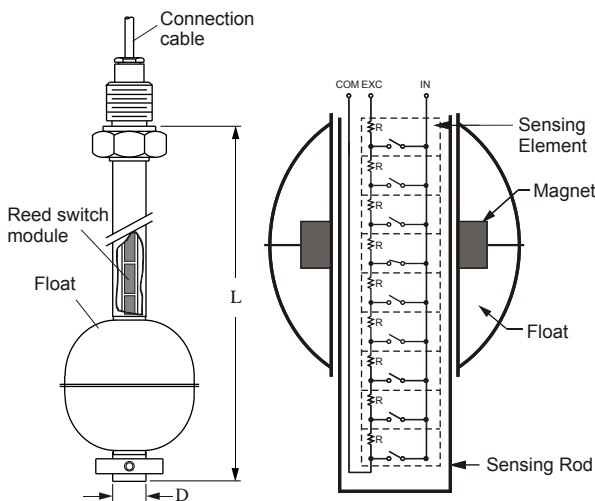

Sensing Element Size

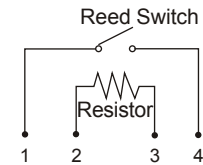
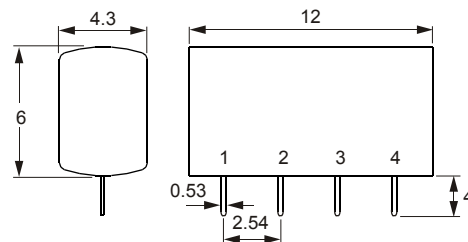

Fig.2

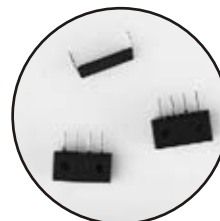

Fig.1
Sensing Element

HOUSING DIMENSION

B

Material : Aluminum
Enclosure : IP65
Max.Temp.: -20°C ~200°C

C

Material : P.P.+Fiber
Enclosure : IP65
Max.Temp.: -20°C ~80°C

D Explosion-proof

Material : Aluminum
Enclosure : NEPSI Ex d IIC T3~T6
ATEX II 2G EEx d IIB T3~T6
ATEX II 2D IP65 T3~T6
Max.Temp.: -20°C ~200°C

G

Material : PC
Enclosure : IP65
Max.Temp.: -20°C ~80°C

K Explosion-proof

Material : Aluminum
Enclosure : CESI 03 ATEX 108
ATEX II 2G EEx d IIC T6
Max.Temp.: -20°C ~100°C

N Explosion-proof

Material : SUS316
Enclosure : NEPSI Ex d IIC T3~T6
ATEX II 2G EEx d IIB T3~T6
ATEX II 2D IP65 T3~T6
Max.Temp.: -20°C ~200°C

X

Material : Aluminum
Enclosure : IP65
Max.Temp.: -20°C ~100°C

● FLOAT SPECIFICATION

Dimension	Type	AxBxC(mm)	S.G.	Max. Pressure (kg/cm ²)	Material	Max. Temp. (°C)	Approx. Weight (g)
	S3	45x55x15	0.65	12	SUS 316	200°C	37.6
	S6	75x108x19	0.5	10	SUS 304	200°C	165
	S4	52x52x15	0.55	30	SUS 316	200°C	33.4
	S5	75x73x19	0.55	30	SUS 304	200°C	102.4
	S8	100x100x20	0.5	15	SUS 304	200°C	249.7
	S9	150x150x30	0.45	15	SUS 304	200°C	534
	P3	48x45x18.5	0.6	5	PP	80°C	35.5
	F4	48x62x18	0.75	5	PVDF	120°C	65.3

TRANSDUCER

Model : RAB-2110 Tranducer

Power Supply : 12~36Vdc
 Output Current : Loop power 4~20mA
 Load Resistance : $RL(\text{Max})=50(\text{Vs}-8)$
 Ambient Temperature : -40~80°C
 Ambient Humidity : 0~80% RH
 Accuracy : $\pm 0.1\%(25^\circ\text{C})$
 Temperature Effect : 0.01%F.S./°C
 Adjustment Range : Span Ajustment 20% FS
 Zero Ajustment 5% FS

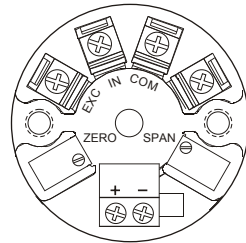

2-Wire (RAB-2110)

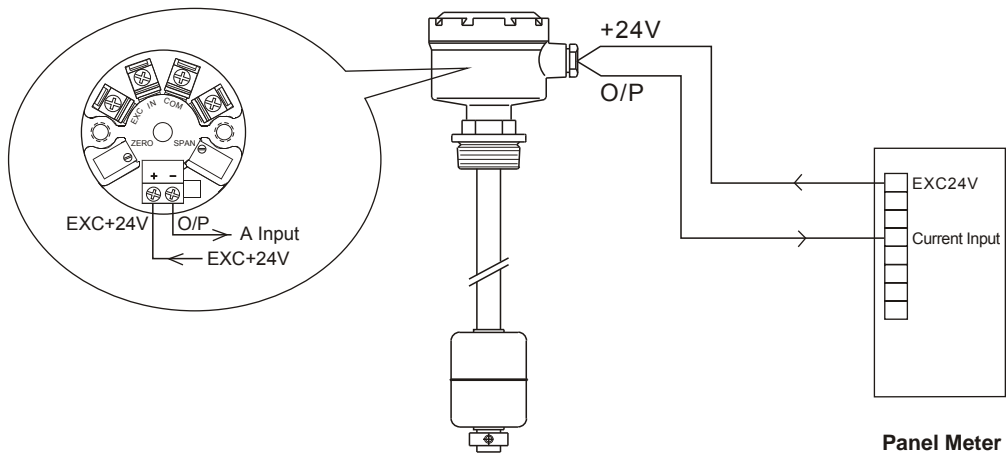

ECONOMICAL

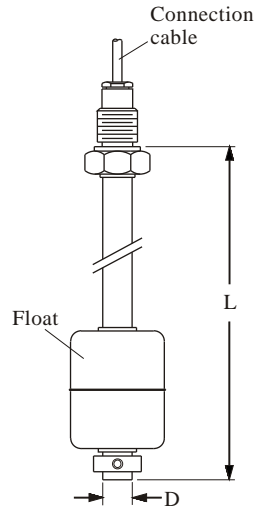
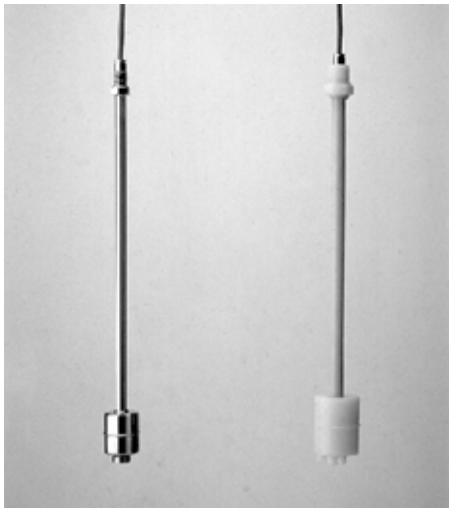

● SPECIFICATION

Connection Cable: Silicon cable 3C × 1M
Output: 3-wire resistance output

Operating Temp.: PP tube -10 °C ~ 80 °C
 PVDF tube -20 °C ~ 120 °C
 SUS tube -20 °C ~ 120 °C

Order No.	Connecting	Tube size & Material (D)	Float type & Material	Suitable S.G.	Measuring Range
LTF_ - AR4	3/8"PF	φ14 SUS 304 SUS 316	S3: φ45x55 SUS 316 S4: φ52x52 SUS 316	>0.65 >0.55	FGA...Max.6M FGB...Max.6M
LTF_ - AR7	3/8"PF	φ17.2 SUS 304	S5: φ75x73 SUS 304 S6: φ75x108	>0.55 >0.5	FGA...Max.6M FGB...Max.6M
LTFB - CR5P3	3/4"PF	φ17.2 PP	P3: φ48x45 PP	>0.6	FGB...Max.6M
LTFB - CR6F4	3/4"PF	φ16 PVDF	F4: φ48x62 PVDF	>0.75	FGB...Max.6M

MODEL : LTF -

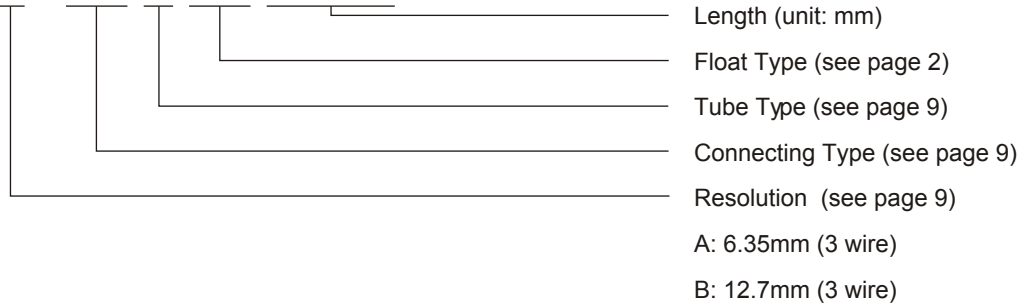

STANDARD

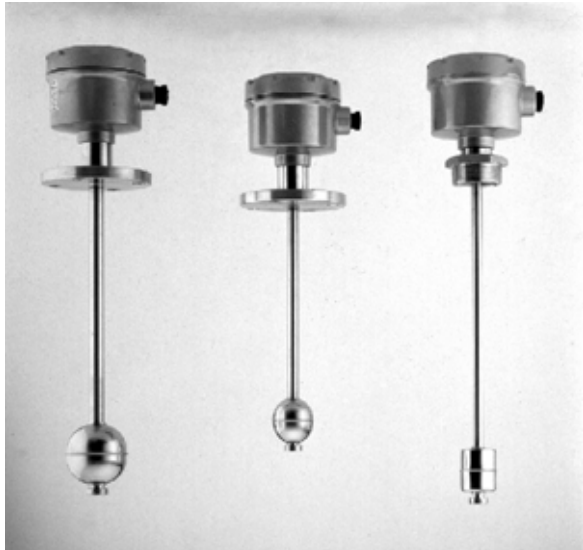

★ B type housing, dimension see page 2.

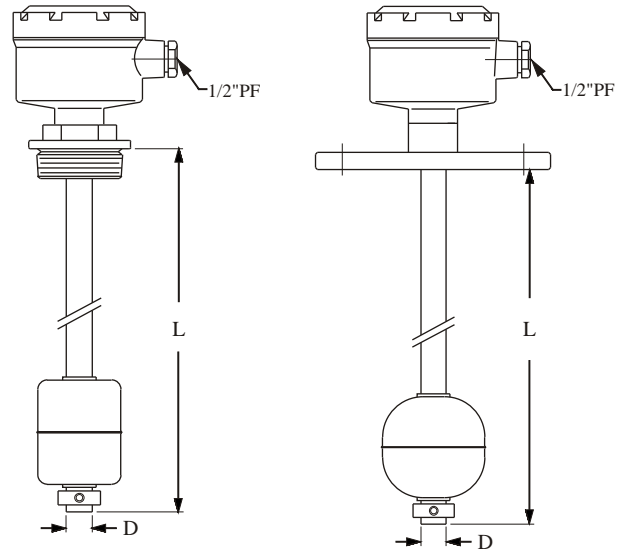

● SPECIFICATION

Terminal Housing: Aluminum, IP65
Output: 4~20mA, 2-wire resistance output
Total resistance value: 1MΩ (Max.)

Operating Temp.: -20 °C ~ 120 °C
Ambient Temp.: 0~70 °C

Order No.	Connecting	Tube size & Material (D)	Float type & Material	Suitable S.G.	Measuring Range
LTF_BFQ4	2"NPT	φ14 SUS 316 SUS 304	S3: φ45x55 SUS 316 S4: φ52x52 SUS 316	>0.65 >0.55	Max. 6m
LTF_BGN4	2-1/2"x10kg/cm ²	φ14 SUS 316 SUS 304	S3: φ45x55 SUS 316 S4: φ52x52 SUS 316	>0.65 >0.55	Max. 6m
LTFDBHN7	3"x10kg/cm ²	φ17.2 SUS 304	S5: φ75x73 SUS 304 S6: φ75x108 SUS 304	>0.55 >0.5	Max. 6m
LTFDBIQ7	4"NPT	φ17.2 SUS 304	S8: φ100x100 SUS 304	>0.5	Max. 6m
LTFDBKN8 LTFDBKN9	6"x10kg/cm ²	φ21.7 φ27.2 SUS 304	S9: φ150x150 SUS 304	>0.45	Max. 12M

MODEL : LTF B

- _____ Length (unit: mm)
- _____ Float Type (see page 2)
- _____ Tube Type (see page 9)
- _____ Connecting Type (see page 9)
- _____ Housing Type (see page 2)
- _____ Resolution (see page 9)
- C: 6.35mm (2 wire)
- D: 12.7mm (2 wire)

ANTI-ACID / ALKALINE

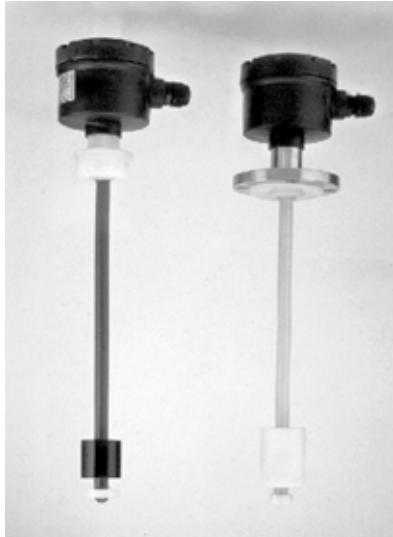

★ C type housing, dimension see page 2.

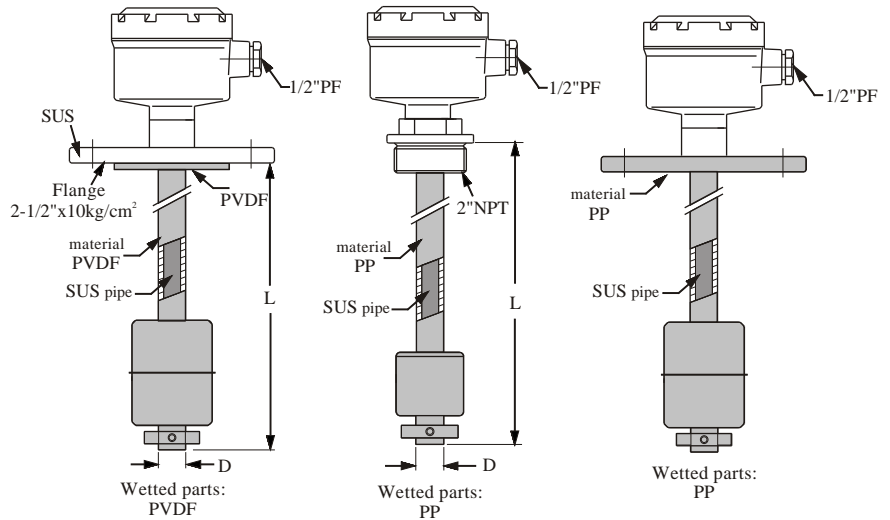

● SPECIFICATION

Terminal Housing: PP +Fiber, IP65
Output: 4~20mA, 2-wire resistance output
Ambient Temp.: 0~70 °C

Operating Temp.: PP jacket tube -10 °C ~ 80 °C
 PVDF jacket tube -20 °C ~ 120 °C
Total resistance value: 1MΩ (Max.)

Order No.	Connecting	Tube size & Material (D)	Float type & Material	Suitable S.G.	Measuring Range
LTFDCFQ5P3	2"NPT	φ17.2 PP	P3: φ48x45 PP	>0.55	Max. 6m
LTFDCFQ6F4	2"NPT	φ16 PVDF	F4: φ48x62 PVDF	>0.75	Max. 6m
LTFDCGN5P3	2-1/2"x10kg/cm ²	φ17.2 PP	P3: φ48x45 PP	>0.6	Max. 6m
LTFDCGN6F4	2-1/2"x10kg/cm ²	φ16 PVDF	F4: φ48x62 PVDF	>0.75	Max. 6m

Every unit is protected by PP or PVDF flange to prevent the sensing rod from chemical corrosion.

MODEL LTF D C



★K type ATEX Explosion proof Enclosure can be selected, dimension see page 2.

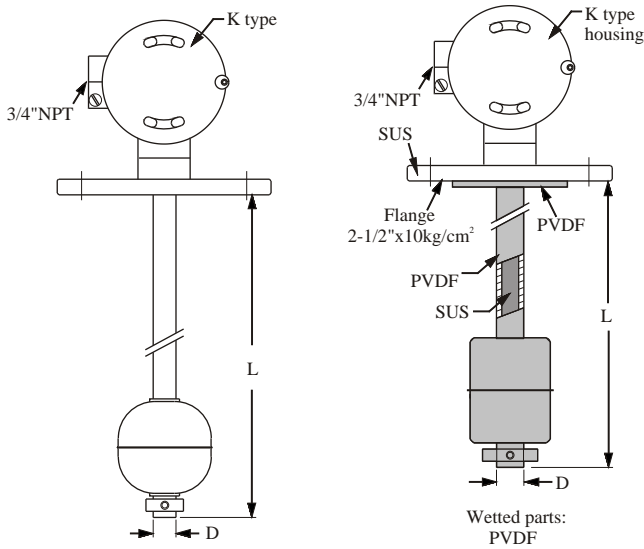

● SPECIFICATION

Terminal Housing: K type --- Aluminum, ATEX EEx d IIC T6	Operating Temp.: PP tube	-10°C ~ 80°C
Output: 4~20mA, 2-wire resistance output	PVDF tube	-20°C ~ 120°C
Ambient Temp.: 0~70 °C	SUS tube	-20 °C ~ 120°C
Total resistance value: 1MΩ (Max.)		

Order No.	Connecting	Tube size & Material (D)	Float type & Material	Suitable S.G.	Measuring Range
LTF_KFQ4	2"NPT	φ14 SUS 304	S4: φ52x52 SUS 316	>0.55	Max. 6M
LTF_KGN4	2-1/2"x10kg/cm ²	φ14 SUS 304	S4: φ52x52 SUS 316	>0.55	Max. 6M
LTFDKHN7	3"x10kg/cm ²	φ17.2 SUS 304	S6: φ75x108 SUS 304	>0.5	Max. 6M
LTFDKIQ4	4"NPT	φ17.2 SUS 304	S8: φ100x100 SUS 304	>0.5	Max. 6M
LTFDKFQ5P3	2"NPT	φ17.2 PP	P3: φ48x45 PP	>0.6	Max. 6M
LTFDKFQ6F4	2"NPT	φ16 PVDF	F4: φ48x62 PVDF	>0.75	Max. 6M
LTFDKGN5P3	2-1/2"x10kg/cm ²	φ17.2 PP	P3: φ48x45 PP	>0.6	Max. 6M
LTFDKGN6F4	2-1/2"x10kg/cm ²	φ16 PVDF	F4: φ48x62 PVDF	>0.75	Max. 6M

MODEL : LTF

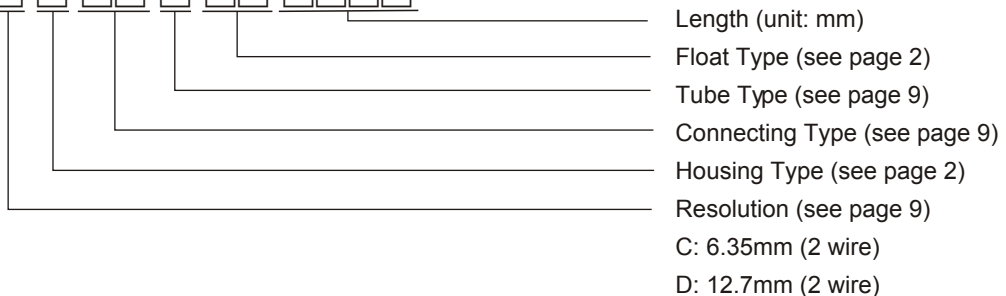

MULTI-FUNCTION



- Double insulations to prevent damage on PCB by moisture.
- Data can be displayed by LCD panel on transmitter.
- Power supply: 12~36 Vdc
- Photo Coupler * 2
- Reed module designed with protective housing to ensure stability and to prevent damage from transportation, installation and operation.
- Accuracy is not affected by modification of temperature, pressure.
- Circuit design is stable and reliable.



● SPECIFICATION

Terminal Housing: Aluminum/PP+Fiber (IP65)

Measured Total Resistance: 1K~2MW

Output: 2 Wire 4~20mA Output

Ambient Temp.: -40~80°C

Operation Temp.:

P.P.: -10°C~80°C

PVDF: -20°C~120°C

Power Supply: Loop Power 12~36Vdc

Output Current: 4~20mA

Output Linear Range: 3.8~21.5mA

Output Latch: 3.5mA, 22mA (Please reboot to delatch)

Upper Output: 22mA

Lower Output: 3.5mA

LCD Display: -1999~9999

Load Resistance: $RL = (Vs - 12) * 50 W$

Environment Humidity: 0~80% RH

Accuracy: 0.1%F.S. (25°C)

Temperature Coefficient: $\pm 0.01\% FS/^\circ C$

Alarm Output:

Mode: Photo coupler x 2

Contact Capacity: 8~30Vdc (50mA)

Operation Model: Alarm: Process High Alarm/
Process Low Alarm

LTF□ F Series Standard Model

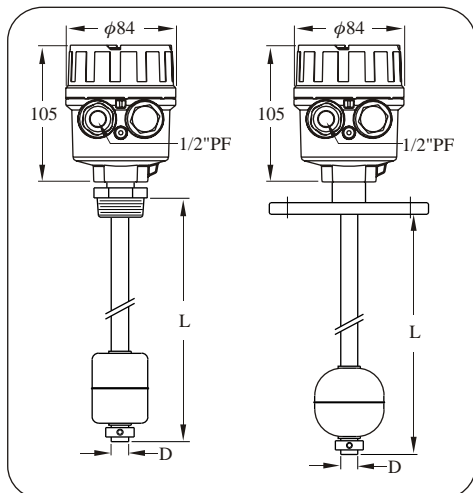

LTF□ F Series Anti-Acid/Alkaline Model

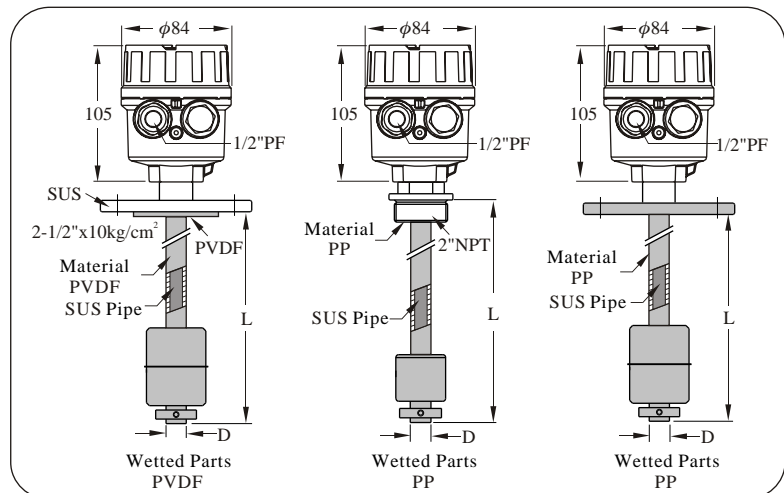



ORDER INFORMATION

LTF **D** **C** **FQ** **6** **F1** **1500** **(P)**

RESOLUTION

- A: 6.35mm (3-wire)
- B : 12.7mm (3-wire)
- C : 6.35mm (2-wire)
- D: 12.7mm (2-wire)
- S : Others
- E: 6.35mm (Multi-Function)
- F: 12.7mm (Multi-Function)
- G: 6.35mm (Multi-Function+HART)
- H: 12.7mm (Multi-Function+HART)

TERMINAL HOUSING (see page 2)

- B : Aluminum (IP65)
- C : P.P (IP65)
- D: Aluminum (Ex d IICT3~T6)
- E: AL. (Small space) IP65
- G: PC (IP65)
- K: Aluminum (EEx dIIC T3~T6)
- N: SUS (E \neq IICT3~T6)
- F : Aluminum
- : None
- S : Others

CONNECTING TYPE

Dimension		Specification	
A: 3/8" (10A)	H: 3" (80A)	M: 5 Kg/cm ²	U : NPT
B: 1/2" (15A)	I : 4" (100A)	N:10 Kg/cm ²	V : GAS
C: 3/4" (20A)	J : 5" (125A)	O: 150 Lbs	S : Others
D: 1" (25A)	K: 6" (150A)	P: 300 Lbs	
E: 1 1/2" (40A)	4 : 7" (175A)	Q: PT	
F: 2" (50A)	5 : 8" (200A)	R: PF(G)	
G: 2 1/2" (65A)		T : BSP	

※ Tri-Clamp 1-1/2"=ES; 2"=FS

TUBE TYPE & MATERIAL

- 0: ϕ 12.7 (SUS304) Only available for resolution 12.7mm.
- 4: ϕ 14 (SUS304)
- 5: ϕ 17.2 (P.P.)
- 6: ϕ 16 (PVDF)
- 7: ϕ 17.2 (SUS304)
- 8: ϕ 21.7 (SUS304)
- 9: ϕ 27.2 (SUS304)
- C: ϕ 12.7 (SUS316) Only available for resolution 12.7mm.
- B: ϕ 14 (SUS316)
- D: ϕ 17.2 (SUS316)
- E: ϕ 21.7 (SUS316)
- F: ϕ 27.2 (SUS316)

FLOAT TYPE (see page 2)

Material	Type					
Plastic	P3	F4				
SUS	S3	S4	S5	S6	S8	S9

- : None

LENGTH (UNIT : mm)

- 0500**: 500mm up ※ 500mm per Unit
- 1000**: 501~1000mm
- 1500**: 1001~1500mm

PIPE SHIELD

- ★ Tolerance of the total product length is ± 5 mm.
- ★ Characteristics, specifications and dimensions are subject to change without notice.
- ★ Please contact us for further informations.

ENCLOSURE EXPLOSION PROOF

★ D or N type housing can be selected.

NEPSI PROOF No.GYJ06231 Ex d IIC T3~T6
 PTB PROOF No.05 ATEX 1028 $\text{Ex II 2G EEx d IIB T3~T6}$
 $\text{Ex II 2D IP65 T3~T6}$

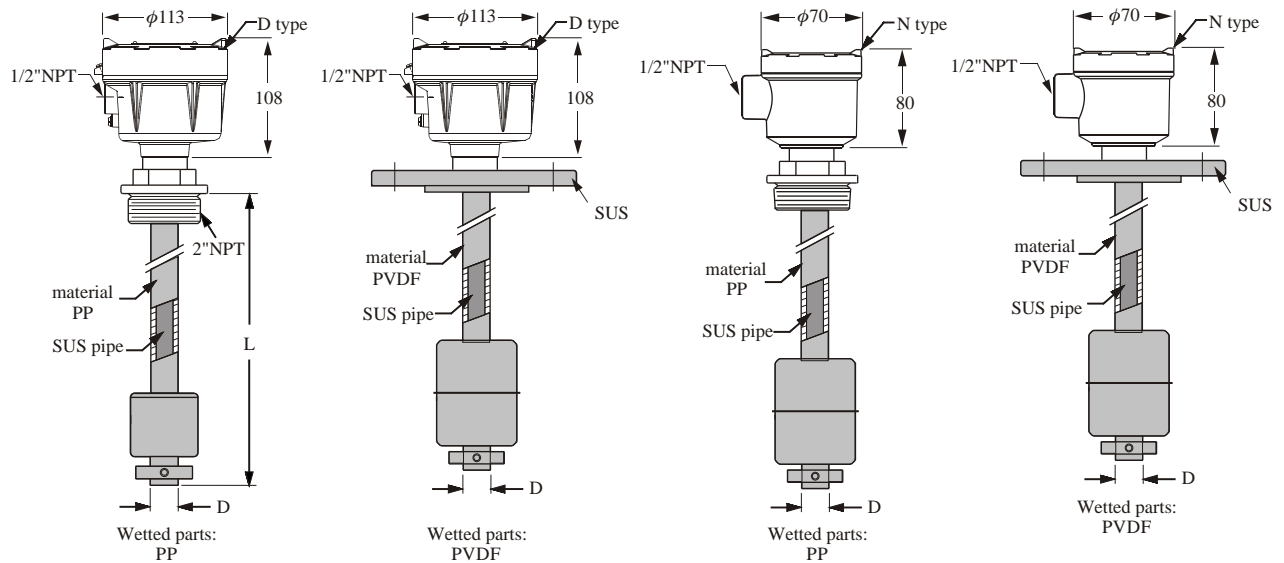

● SPECIFICATION

Terminal Housing: D type --- Aluminum, Ex d IIB T3~T6
 N type --- SUS, Ex d IIC T3~T6

Output: 4~20mA, 2-wire resistance output

Ambient Temp.: 0~70 °C

Total Resistance Value.: 1MΩ (Max.)

Operation Temp.: PP tube -10 °C ~ 80 °C

PVDF tube -20 °C ~ 120 °C

ORDER NO. FG7 MODEL NO. RL7	Connecting	Tube size (D) & Material	Float type & Material	Suitable S.G.	Measuring Range
LTF7_DFQ4	2"NPT	φ14 SUS 316	S3: φ45x55 SUS 316	>0.65	RL7...Max.3M
LTF7_DGN4	2-1/2"x10kg/cm ²	φ14 SUS 316	S3: φ45x55 SUS 316	>0.65	RL7...Max.3M
LTF7DDHN7	3"x10kg/cm ²	φ17.2 SUS 304	S5: φ75x73 SUS 304	>0.55	RL7...Max.6M
LTF7DDIQ4	4"NPT	φ17.2 SUS 304	S8: φ100x100 SUS 304	>0.5	RL7...Max.6M
LTF7DDKN8 LTF7DDKN9	6"x10kg/cm ²	φ21.7 φ27.2 SUS 304	S9: φ150x150 SUS 304	>0.45	RL7...Max.6M
LTF7DDFQ5P3	2"NPT	φ17.2 PP	P3: φ48x45 PP	>0.6	RL7...Max.6M
LTF7DDFQ6F4	2"NPT	φ16 PVDF	F4: φ48x62 PVDF	>0.75	RL7...Max.6M
LTF7DDGN5P3	2-1/2"x10kg/cm ²	φ17.2 PP	P3: φ48x45 PP	>0.6	RL7...Max.6M
LTF7DDGN6F4	2-1/2"x10kg/cm ²	φ16 PVDF	F4: φ48x62 PVDF	>0.75	RL7...Max.6M



ORDER NAME INFORMATION

Order No. LTF7 **D** **D** **FQ** **6** **F1** **1500** (L)

RESOLUTION

- A : 6.35mm (3-wire)
- B : 12.7mm (3-wire)
- C : 6.35mm (2-wire)
- D : 12.7mm (2-wire)

TERMINAL HOUSING (see page 2)

- D: AL (Ex d IICT3~T6)
- N: SUS (Exd IIC T3~T6)

CONNECTING TYPE

Dimension		Specification	
A : 3/8" (10A)	H: 3" (80A)	M: 5 Kg/cm ²	U: NPT
B : 1/2" (15A)	I: 4" (100A)	N: 10 Kg/cm ²	V: GAS
C : 3/4" (20A)	J: 5" (125A)	O: 150 Lbs	S: Others
D : 1" (25A)	K: 6" (150A)	P: 300 Lbs	
E : 1 1/2" (40A)	4: 7" (175A)	Q: PT	
F : 2" (50A)	5: 8" (200A)	R: PF(G)	
G : 2 1/2" (65A)		T: BSP	

TUBE TYPE & MATERIAL

- | | |
|---------------------------------------|---------------------------------------|
| 0: ϕ 12.7 (SUS) | C: f12.7 (SUS316) |
| Only available for resolution 12.7mm. | Only available for resolution 12.7mm. |
| 4: ϕ 14 (SUS) | B: f14 (SUS316) |
| 5: ϕ 17.2 (P.P.) | D: f17.2 (SUS316) |
| 6: ϕ 16 (PVDF) | E: f21.7 (SUS316) |
| 7: ϕ 17.2 (SUS) | F: f27.2 (SUS316) |
| 8: ϕ 21.7 (SUS) | |
| 9: ϕ 27.2 (SUS) | |

FLOAT TYPE (see page 2)

Material	Type					
	Plastic	P3	F4			
SUS	S3	S4	S5	S6	S8	S9

LENGTH (UNIT : mm)

- 0500: 500mm up
 - 1000: 501~1000mm
 - 1500: 1001~1500mm
 - ⋮
- ※ 500mm per Unit

TAG

- ★ Tolerance of the total product length is ± 5 mm.
- ★ Characteristics, specifications and dimensions are subject to change without notice.
- ★ Please contact us for further informations.

INSTALLATION

- ▶ The float level indicator should be mounted far away from liquid inlet, Any strong liquid fluctuation will produce error output signals.

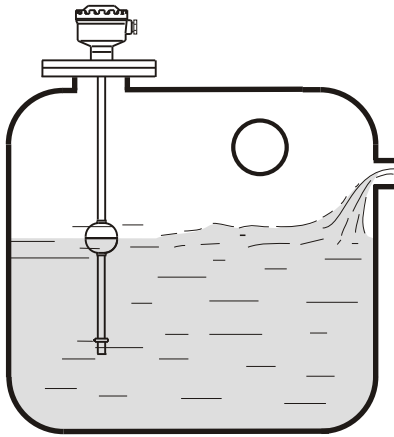

- ▶ It is requested a pipe shield or equivalent device to normalize the indicator actuation if the indicator is used with any agitator application.

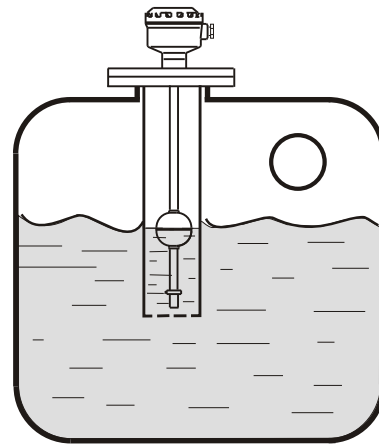

- ▶ It had better require an L type supporter, when the level indicator is mounted in concrete wall tank as figure below.

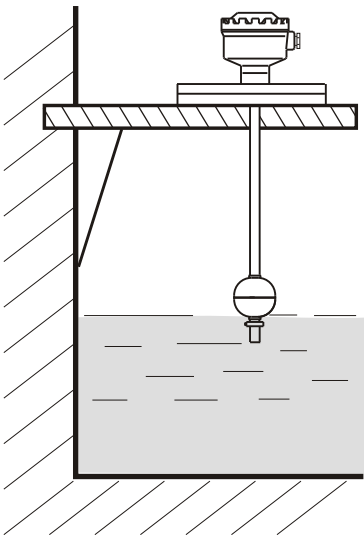

- ▶ It is recommended to select the standpipe with diameter(d) larger than the float ball for Installation process.

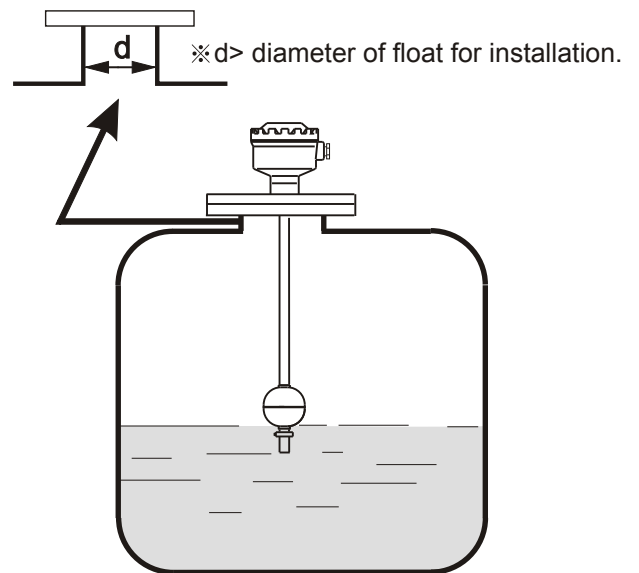



RLT Instrumentation Pvt. Ltd.,

*#2, Rangarajapuram 1st Street,
Kodambakkam,
Chennai - 600 024.
Tamil Nadu, India*

*Ph : 044-24806500(10-Lines)
Fax : 044-24806555,
E-mail : chennai@rltech.in
Website : www.rltech.in*